

General Specifications

EJA210E
Flange Mounted
Differential Pressure Transmitter



GS 01C31C01-01EN

The high performance flange mounted differential pressure transmitter EJA210E can be used to measure levels of densities of solidifying or precipitating liquids. EJA210E outputs a 4 to 20 mA DC signal corresponding to the measured differential pressure. Its accurate and stable sensor can also measure the static pressure which can be shown on the integral indicator or remotely monitored via BRAIN or HART communications. Other key features include quick response, remote set-up using communications and self-diagnostics. FOUNDATION Fieldbus and PROFIBUS PA protocol types are also available. All EJA-E series models in their standard configuration, with the exception of the Fieldbus and PROFIBUS types, are certified as complying with SIL 2 for safety requirement.



STANDARD SPECIFICATIONS

Refer to GS 01C31T02-01EN for Fieldbus communication type and GS 01C31T04-01EN for PROFIBUS PA communication type for the items marked with “◇”.

SPAN AND RANGE LIMITS

Measurement Span/Range	kPa	inH ₂ O (D1)	mbar (D3)	mmH ₂ O (D4)	
M	Span	1 to 100	4 to 400	10 to 1000	100 to 10000
	Range	-100 to 100	-400 to 400	-1000 to 1000	-10000 to 10000
H	Span	5 to 500	20 to 2000	50 to 5000	0.05 to 5 kgf/cm ²
	Range	-500 to 500	-2000 to 2000	-5000 to 5000	-5 to 5 kgf/cm ²

PERFORMANCE SPECIFICATIONS

Zero-based calibrated span, linear output, wetted parts material code SW for 3-inch flange flush type, and fill fluid code B. For Fieldbus and PROFIBUS PA communication types, use caribrated range instead of span in the following specifications.

Specification Conformance

EJA-E series ensures specification conformance to at least $\pm 3\sigma$.

Reference Accuracy of Calibrated Span

(includes terminal-based linearity, hysteresis, and repeatability)

Measurement span	M	
Reference accuracy	X \leq span	$\pm 0.075\%$ of Span
	X $>$ span	$\pm(0.025+0.005 \text{ URL}/\text{span})\%$ of Span
X	10 kPa (40 inH ₂ O)	
URL (upper range limit)	100 kPa (400 inH ₂ O)	

Measurement span	H	
Reference accuracy	X \leq span	$\pm 0.075\%$ of Span
	X $>$ span	$\pm(0.025+0.01 \text{ URL}/\text{span})\%$ of Span
X	100 kPa (400 inH ₂ O)	
URL (upper range limit)	500 kPa (2000 inH ₂ O)	

Ambient Temperature Effects per 28°C (50°F) Change

Capsule	Effect
M	$\pm(0.14\% \text{ Span}+0.028\% \text{ URL})$
H	$\pm(0.224\% \text{ Span}+0.056\% \text{ URL})$

Static Pressure Effects per 0.69 MPa (100 psi) Change

Span Effects

M and H capsules
 $\pm 0.028\%$ of span

Effect on Zero

M and H capsules
 $\pm 0.007\%$ of URL

Stability

$\pm 0.1\%$ of URL per 12 months

Power Supply Effects(Output signal code D and J)

$\pm 0.005\%$ per Volt (from 21.6 to 32 V DC, 350Ω)

Response Time (Differential pressure) “◇”

M and H capsule: 120 ms (approximate value at normal temperature)

When software damping is set to zero and including dead time of 45 ms (nominal)

Static Pressure Signal Range and Accuracy (For monitoring via communication or on indicator for BRAIN and HART communication type. Includes terminal-based linearity, hysteresis, and repeatability)

Range

Upper Range Value and Lower Range Value of the static pressure can be set in the range between 0 and Maximum Working Pressure (MWP*). The upper range value must be greater than the lower range value. Minimum setting span is 0.5 MPa (73 psi).

* : Maximum Working Pressure (MWP) is within flange rating pressure.

Accuracy

Absolute Pressure

1 MPa or higher: ±0.5% of span

Less than 1 MPa: ±0.5%×(1 MPa/span) of span

Gauge Pressure Reference

Gauge pressure reference is 1013 hPa (1 atm)

Note: Gauge pressure variable is based on the above fixed reference and thus subject to be affected by the change of atmospheric pressure.

□ **FUNCTIONAL SPECIFICATIONS**

Output “◇”

Two wire 4 to 20 mA DC output with digital communications.

BRAIN or HART FSK protocol are superimposed on the 4 to 20 mA signal.

Output range: 3.6 mA to 21.6 mA

Output limits conform to NAMUR NE43 can be preset by option code C2 or C3.

Failure Alarm (Output signal code D and J)

Output status at CPU failure and hardware error;

Up-scale: 110%, 21.6 mA DC or more (standard)

Down-scale: -5%, 3.2 mA DC or less

Damping Time Constant (1st order)

Amplifier damping time constant is adjustable from 0.00 to 100.00 s by software and added to response time.

Note: For BRAIN protocol type, when amplifier software damping is set to less than 0.5 s, communication may occasionally be unavailable during the operation, especially while output changes dynamically. The default setting of damping ensures stable communication.

Update Period “◇”

Differential pressure: 45 ms

Static pressure: 360 ms

Zero Adjustment Limits

Zero can be fully elevated or suppressed, within the lower and upper range limits of the capsule.

External Zero Adjustment

External zero is continuously adjustable with 0.01% incremental resolution of span. Re-range can be done locally using the digital indicator with rangesetting switch.

Integral Indicator (LCD display, optional) “◇”

5-digit numerical display, 6-digit unit display and bar graph.

The indicator is configurable to display one or up to four of the following variables periodically.;

Measured differential pressure, differential pressure in %, scaled differential pressure, measured static pressure. See also “Factory Setting.”

Self Diagnostics

CPU failure, hardware failure, configuration error, process alarm for differential pressure, static pressure or capsule temperature.

User-configurable process high/low alarm for differential pressure and static pressure is also available.

Signal Characterizer (Output signal code D and J)

User-configurable 10-segment signal characterizer for 4 to 20 mA output.

SIL Certification

EJA-E series transmitters except Fieldbus and PROFIBUS PA communication types are certified in compliance with the following standards;

IEC 61508: 2000; Part1 to Part 7

Functional Safety of Electrical/electronic/

programmable electronic related systems; SIL 2

capability for single transmitter use, SIL 3 capability for dual transmitter use.

□ **NORMAL OPERATING CONDITION (Optional features or approval codes may affect limits.)**

Ambient Temperature Limits

-40 to 85°C (-40 to 185°F)

-30 to 80°C (-22 to 176°F) with LCD display

(Note: The ambient temperature limits must be within the fill fluid operating temperature range, see table 1.)

Process Temperature Limits

High pressure side: See table 1.

Low pressure side: -40 to 120°C (-40 to 248°F)

Ambient Humidity Limits

0 to 100% RH

Working Pressure Limits

See table 1.

For atmospheric pressure or below, see figure 1.

Supply & Load Requirements (Output signal code D and J. Optional features or approval codes may affect electrical requirements.)

With 24 V DC supply, up to a 550Ω load can be used. See figure 2.

Supply Voltage “◇”

10.5 to 42 V DC for general use and flameproof type.

10.5 to 32 V DC for lightning protector

(option code /A.)

10.5 to 30 V DC for intrinsically safe, type n, or non-incendive.

Minimum voltage limited at 16.6 V DC for digital communications, BRAIN and HART

Load (Output signal code D and J)

0 to 1290Ω for operation

250 to 600Ω for digital communication

Communication Requirements “◇”

(Approval codes may affect electrical requirements.)

BRAIN

Communication Distance

Up to 2 km (1.25 miles) when using CEV

polyethylene-insulated PVC-sheathed cables.

Communication distance varies depending on type of cable used.

Load Capacitance

0.22 μF or less

Load Inductance

3.3 mH or less

Input Impedance of communicating device

10 kΩ or more at 2.4 kHz.

EMC Conformity Standards  , 

EN61326-1 Class A, Table2 (For use in industrial locations)

EN61326-2-3

EN61326-2-5 (for PROFIBUS only)

European Pressure Equipment Directive 97/23/EC

Sound Engineering Practice

Safety Requirement Standards

EN61010-1

- Altitude of installation site: Max. 2,000 m above sea level
- Installation category: I
- Pollution degree: 2
- Indoor/Outdoor use

Table 1. Process temperature, Ambient temperature, and Working pressure

	Code	Process temperature*1*2	Ambient temperature*3	Working pressure
Silicone oil (high temperature use)	A	-10 to 250°C *4 (14 to 482°F)	-10 to 85°C (14 to 185°F)	2.7 kPa abs (0.38 psi abs) to flange rating pressure
Silicone oil (general use)	B	-40 to 120°C (-40 to 248°F)	-40 to 85°C (-40 to 185°F)	
Fluorinated oil (Oil-prohibited use)	D	-20 to 120°C *5 (-4 to 185°F)	-20 to 80°C (-4 to 176°F)	51 kPa abs (7.4 psi abs) to flange rating pressure
Plopylene glycol	P	-10 to 120°C (-14 to 248°F)	-10 to 85°C (14 to 185°F)	100 kPa abs (atmospheric pressure) to flange rating pressure

*1: See figure 1 'Working Pressure and Process Temperature.'

*2: Indicates high pressure side value. The process temperature limit for low pressure side is -40 to 120°C (-40 to 248°F).

*3: This ambient temperature is the transmitter ambient temperature.

*4: In case of wetted parts material code TW (Tantalum), process temperature limit is up to 200°C (392°F).

*5: The process temperature limit for lower pressure side is -20 to 80°C (-4 to 176°F).

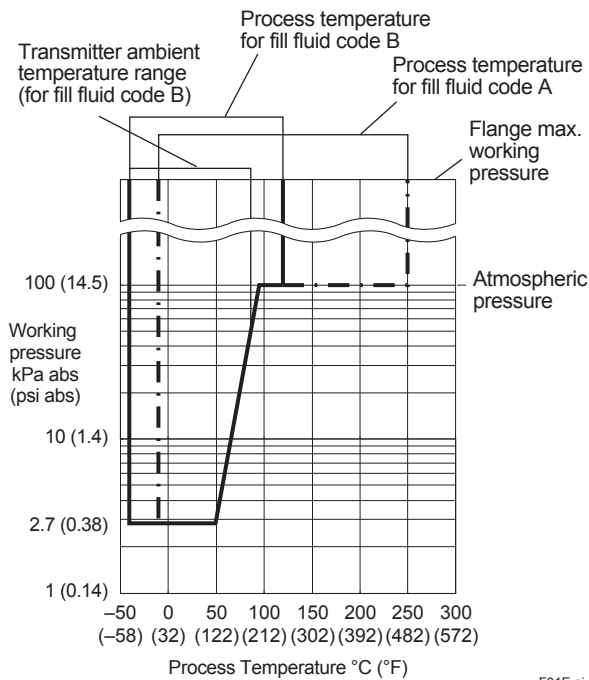

Figure 1. Working Pressure and Process Temperature (Fill fluid: silicone oil for general and high temperature use)

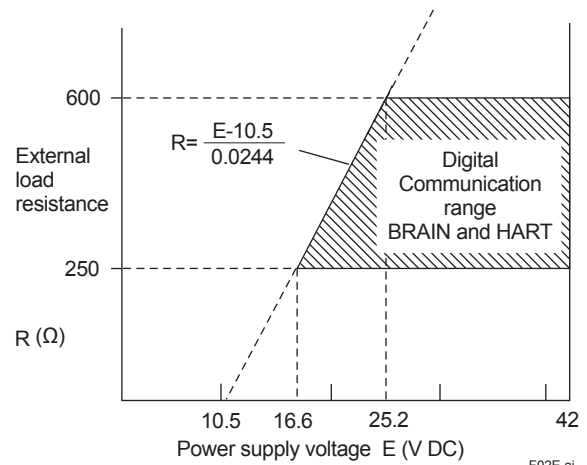

Figure 2. Relationship Between Power Supply Voltage and External Load Resistance

□ **PHYSICAL SPECIFICATIONS**

Process connections

High pressure side:

Flange connected
See the following table.

Table 2. Flange size and rating

Process connection style	Size	Flange
Flush type	3-inch 2-inch 1 1/2-inch*	JIS 10K, 20K ANSI Class 150, 300 JPI Class 150, 300 DIN PN10/16, 25/40
Extended type	4-inch 3-inch	JIS 10K, 20K ANSI Class 150, 300 JPI Class 150, 300 DIN PN10/16, 25/40

* : Flushing connection rings are always attached.

Low pressure side:

Threaded
See "MODEL AND SUFFIX CODES."
Process connection of cover flange: IEC61518

Gasket Contact Surface

See the following table.

Table 3. Gasket contact surface

Flange		JIS/JPI/DIN		ANSI	
Wetted parts material code		SW, SE, WW, WE	HW, TW	SW, SE, WW, WE	HW, TW
Gasket contact Surface	Serration*1	—	—	●	—
	Flat (No serration)	●	●	●	●

● : Applicable
— : Not applicable
*1: ANSI B16.5

Electrical Connections

See "MODEL AND SUFFIX CODES."

Wetted Parts Materials

High pressure side:

Refer to "MODEL AND SUFFIX CODES"

Flushing connection ring (optional)

Ring and Vent/Drain plugs

Refer to "MODEL AND SUFFIX CODES"

(Spiral) gasket for transmitter side

316L SST (Hoop), PTFE Teflon (Filler)

Low pressure side:

Diaphragm, Cover Flange, Process Connector, Capsule Gasket, and Vent/Drain plug
Refer to "MODEL AND SUFFIX CODES"

Process connector gasket

PTFE Teflon

Non-wetted Parts Materials

Process Flange

Refer to "MODEL AND SUFFIX CODES"

Bolting

B7 carbon steel, 316L SST or 660 SST

Housing

Low copper cast aluminum alloy with polyurethane, deep sea moss green paint (Munsell 0.6GY3.1/2.0 or its equivalent) or ASTM CF-8M stainless steel

Degrees of Protection

IP66/IP67, NEMA TYPE 4X

Cover O-rings

Buna-N, fluoro-rubber (optional)

Name plate and tag

316 SST

Fill Fluid

Silicone oil, Plopylene glycol, Fluorinated oil (optional)

Weight

Flush type

(3-inch ANSI Class150 flange; without integral indicator, and process connector.)

General use (fill fluid code B or P): 8.3 kg (18.3 lbs)

High temperature use (fill fluid code A):

9.0 kg (19.8 lbs)

Extended type

(4-inch ANSI Class150 flange, extension length (X₂) = 100 mm; without integral indicator, and process connector.)

General use (fill fluid code B or P): 12.8 kg (28.2 lbs)

High temperature use (fill fluid code A):

13.5 kg (29.8 lbs)

Add 1.5kg (3.3lb) for Amplifier housing code 2.

< **Related Instruments** > "◇"

Power Distributor: Refer to GS 01B04T01-02E or GS 01B04T02-02E

BRAIN TERMINAL: Refer to GS 01C00A11-00E

< **Reference** >

- **DPHarp EJA** is a registered trademark of Yokogawa Electric Corporation.
- FieldMate; Trademark of Yokogawa Electric Corporation.
- Teflon; Trademark of E.I. DuPont de Nemours & Co.
- Hastelloy; Trademark of Haynes International Inc.
- HART; Trademark of the HART Communication Foundation.
- FOUNDATION Fieldbus; Trademark of Fieldbus Foundation.
- PROFIBUS; Registered trademark of Profibus Nutzerorganisation e.v., Karlsruhe, Germany.

Other company names and product names used in this material are registered trademarks or trademarks of their respective owners.

■ MODEL AND SUFFIX CODES

● Instruction

The model and suffix codes for EJA210E consist of two parts; a transmitter body section (I) and a flange mounting section (II). This specification sheet introduces these two parts separately. The transmitter body section is shown in one table, and the flange mounting section specifications are listed according to the flange size and the process connection style. First select the model and suffix codes of transmitter body section and then continue on one of the flange mounting section.

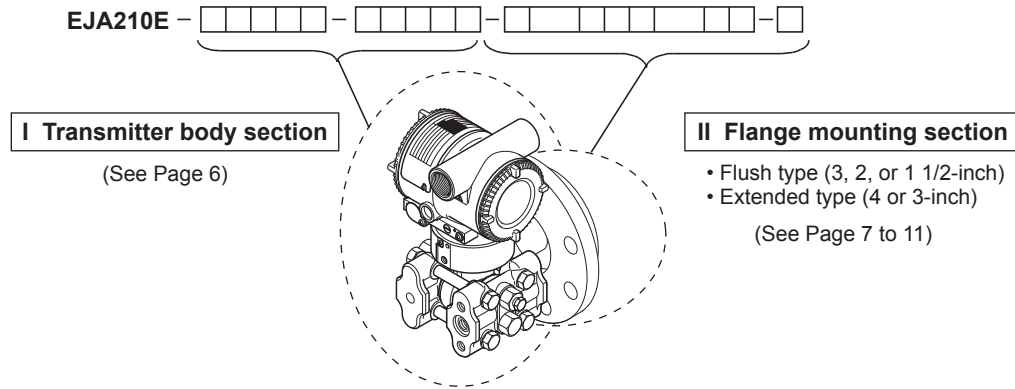

F03E.ai

I. Transmitter body section

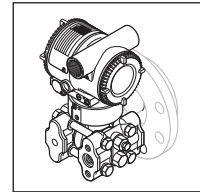

F04_1E.ai

Model	Suffix Codes	Description
EJA210E	Flange mounted differential pressure transmitter
Output signal	-D -J -F -G	4 to 20 mA DC with digital communication (BRAIN protocol) 4 to 20 mA DC with digital communication (HART 5/HART 7 protocol)*1 Digital communication (FOUNDATION Fieldbus protocol, refer to GS 01C31T02-01EN) Digital communication (PROFIBUS PA protocol, refer to GS 01C31T04-01EN)
Measurement span (capsule)	M H	1 to 100kPa (4 to 400 inH ₂ O) 5 to 500kPa (20 to 2000 inH ₂ O)
Low pressure side wetted parts material	S	Refer to "Low Pressure Side Wetted Parts Materials" Table below.
Low pressure side Process connections	0 1 2 3 4 5	without process connector (Rc 1/4 female on the cover flange) with Rc 1/4 female process connector with Rc 1/2 female process connector with 1/4 NPT female process connector with 1/2 NPT female process connector without process connector (1/4 NPT female on the cover flange)
Coverflange bolts and nuts material	J G C	B7 carbon steel 316L SST 660 SST
Installation	-9	Horizontal piping type and left side high pressure
Amplifier housing	1 3 2	Cast aluminum alloy Cast aluminum alloy with corrosion resistance properties*2 ASTM CF-8M stainless steel*3
Electrical connection	0 2 4 5 7 9 A C D	G 1/2 female, one electrical connection without blind plugs 1/2 NPT female, two electrical connections without blind plugs M20 female, two electrical connections without blind plugs G 1/2 female, two electrical connections with a blind plug *4 1/2 NPT female, two electrical connections with a blind plug *4 M20 female, two electrical connections with a blind plug *4 G1/2 female, two electrical connections and a 316 SST blind plug 1/2 NPT female, two electrical connections and a 316 SST blind plug M20 female, two electrical connections and a 316 SST blind plug
Integral indicator	D E N	Digital indicator*5 Digital indicator with the range setting switch*6 None
—	N	Always N
Flange mounting section		- [] - [] Continued on flange mounting section (II)

The "►" marks indicate the most typical selection for each specification.

- *1: HART 5 or HART 7 is selectable. Specify upon ordering.
- *2: Not applicable for electrical connection code 0, 5, 7, 9 and A. Content rate of copper in the material is 0.03% or less and content rate of iron is 0.15% or less.
- *3: Not applicable for electrical connections code 0, 5, 7 and 9.
- *4: Material of a blind plug is aluminum alloy or 304 SST.
- *5: Not applicable for output signal code G.
- *6: Not applicable for output signal code F.

Table. Low Pressure Side Wetted Parts Materials

Low pressure side wetted parts material code	Cover flange and process connector	Capsule	Capsule gasket	Drain/Vent plug
S #	ASTM CF-8M *1	Hastelloy C-276 *2 (Diaphragm) F316L SST, 316L SST (Others)	Teflon-coated 316L SST	316 SST

*1: Cast version of 316 SST. Equivalent to SCS14A.
 *2: Hastelloy C-276 or ASTM N10276
 The '# marks indicate the construction materials conform to NACE material recommendations per MR0175 (2003). Please refer to latest standards for details.

II. Flange mounting section (Flush type)

- Process flange size: 3-inch (80mm)

EJA210E- [] [] [] [] - [] [] [] [] - W [] 3 [] [] [] [] [] [] [] []

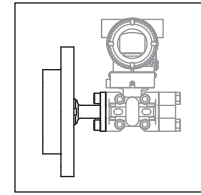

F05_1E.ai

Model	Suffix codes	Description
EJA210E	- [] [] [] [] - [] [] [] []	Transmitter body section (I)
Process connection style	-W	Flush type
Flange rating	J1 J2 A1 A2 P1 P2 D2 D4	JIS 10K JIS 20K ANSI class 150 ANSI class 300 JPI class 150 JPI class 300 DIN PN10/16 DIN PN25/40
Flange size	3	3-inch (80mm)
Flange material	▶ A B C	JIS S25C 304 SST *10 316 SST *10
Gasket contact surface*1	1 2	Serration (for ANSI flange with wetted parts material SW only) Flat (no serration)
Wetted parts material (high pressure side) *9	SW HW TW	[Diaphragm] [Others] 316L SST# 316 SST# Hastelloy C-276 *7# Hastelloy C-276 *7# Tantalum *8 Tantalum *8
Flushing connection ring*2	▶ 0 A B	[Ring] [Vent/Drain plugs] [Material] None — — Straight type R 1/4 connections *6 316 SST # Straight type 1/4 NPT connections 316 SST #
Extension	0	None
Fill fluid	▶ -A ... -B ... -D ... -P ...	[Process temperature]*3 [Ambient temperature] For high temperature use (Silicone oil) -10 to 250°C*4*5 -10 to 85°C For general use (Silicone oil) -40 to 120°C -40 to 85°C For oil prohibited use (Fluorinated oil)*11 -20 to 120°C -20 to 80°C For sanitary use (Propylene glycol) -10 to 120°C -10 to 85°C
Option codes		/□ Optional specification

The “▶” marks indicate the most typical selection for each specification.

Example: EJA210E-DMS5G-912NN-WA13B1SW00-B/□

*1: See Table 3 'Gasket contact surface' on Page 4.

*2: When specified flushing connection ring code A or B, exclusive gasket is provided for transmitter side.

*3: Indicates the process temperature limit of high pressure side.

The process temperature limit for low pressure side is -40 to 120°C except fill fluid code -D.

*4: The distance 'S' is extended in 30mm.

*5: In case of wetted parts material code TW (Tantalum), the process temperature limit is -10 to 200°C.

*6: Not applicable for gasket contact surface code 1.

*7: Hastelloy C-276 or ASTM N10276

*8: Not applicable for flashing connection ring code A and B.

*9: ⚠ Users must consider the characteristics of selected wetted parts material and the influence of process fluids. The use of inappropriate materials can result in the leakage of corrosive process fluids and cause injury to personnel and/or damage to plant facilities. It is also possible that the diaphragm itself can be damaged and that material from the broken diaphragm and the fill fluid can contaminate the user's process fluids.
Be very careful with highly corrosive process fluids such as hydrochloric acid, sulfuric acid, hydrogen sulfide, sodium hypochlorite, and high-temperature steam (150°C [302°F] or above). Contact Yokogawa for detailed information of the wetted parts material.

*10: Forged version of the material may be used.

*11: Specify always with option code /K2 or /K6.

The # marks indicate the construction materials conform to NACE material recommendations per MR0175 (2003).

Please refer to latest standards for details.

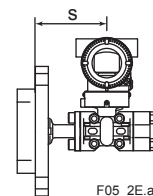

F05_2E.ai

II. Flange mounting section (Flush type)

- Process flange size: 2-inch (50mm)

EJA210E - [] [] [] [] - [] [] [] [] - W [] 2 [] [] [] [] [] [] [] []

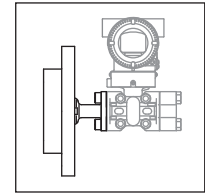

F06_1E.ai

Model	Suffix codes	Description
EJA210E	- [] [] [] [] - [] [] [] []	Transmitter body section (I)
Process connection style	-W	Flush type
Flange rating	J1 J2 A1 A2 P1 P2 D2 D4	JIS 10K JIS 20K ANSI class 150 ANSI class 300 JPI class 150 JPI class 300 DIN PN10/16 DIN PN25/40
Flange size	2	2-inch (50mm)
Flange material	▶ A B C	JIS S25C 304 SST *10 316 SST *10
Gasket contact surface*1	1 2	Serration (for ANSI flange with wetted parts material WW only) Flat (no serration)
Wetted parts material (high pressure side) *9	WW HW TW	[Diaphragm] [Others] Hastelloy C-276 *7# 316 SST# Hastelloy C-276 *7# Hastelloy C-276 *7# Tantalum *8 Tantalum *8
Flushing connection ring*2	▶ 0 A B	[Ring] [Vent/Drain plugs] [Material] None — — Straight type R 1/4 connections *6 316 SST # Straight type 1/4 NPT connections 316 SST #
Extension	0	None
Fill fluid	▶ -A ... -B ... -D ... -P ...	[Process temperature]*3 [Ambient temperature] For high temperature use (Silicone oil) -10 to 250°C*4*5 -10 to 85°C For general use (Silicone oil) -40 to 120°C -40 to 85°C For oil prohibited use (Fluorinated oil)*11 -20 to 120°C -20 to 80°C For sanitary use (Propylene glycol) -10 to 120°C -10 to 85°C
Option codes		/□ Optional specification

The “▶” marks indicate the most typical selection for each specification.

Example: EJA210E-DMS5G-912NN-WA12B1WW00-B/□

*1: See Table 3 'Gasket contact surface' on Page 4.

*2: When specified flushing connection ring code A or B, exclusive gasket is provided for transmitter side.

*3: Indicates the process temperature limit of high pressure side.

The process temperature limit for low pressure side is -40 to 120°C except fill fluid code -D.

*4: The distance 'S' is extended in 30mm.

*5: In case of wetted parts material code TW (Tantalum), the process temperature limit is -10 to 200°C.

*6: Not applicable for gasket contact surface code 1.

*7: Hastelloy C-276 or ASTM N10276

*8: Not applicable for flashing connection ring code A and B.

*9: ⚠ Users must consider the characteristics of selected wetted parts material and the influence of process fluids. The use of inappropriate materials can result in the leakage of corrosive process fluids and cause injury to personnel and/or damage to plant facilities. It is also possible that the diaphragm itself can be damaged and that material from the broken diaphragm and the fill fluid can contaminate the user's process fluids.
Be very careful with highly corrosive process fluids such as hydrochloric acid, sulfuric acid, hydrogen sulfide, sodium hypochlorite, and high-temperature steam (150°C [302°F] or above). Contact Yokogawa for detailed information of the wetted parts material.

*10: Forged version of the material may be used.

*11: Specify always with option code /K2 or /K6.

The # marks indicate the construction materials conform to NACE material recommendations per MR0175 (2003).

Please refer to latest standards for details.

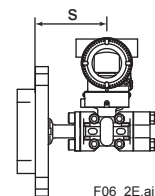

F06_2E.ai

II. Flange mounting section (Flush type)

- Process flange size: 1 1/2-inch (40mm)

EJA210E - [] [] [] [] - [] [] [] [] - W [] 8 [] [] [] [] [] [] [] []

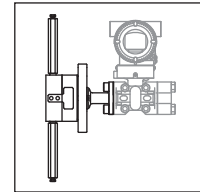

F07_1E.ai

Model	Suffix codes	Description
EJA210E	- [] [] [] [] - [] [] [] []	Transmitter body section (I)
Process connection style	-W.....	Flush type
Flange rating	J1..... J2..... A1..... A2..... P1..... P2.....	JIS 10K JIS 20K ANSI class 150 ANSI class 300 JPI class 150 JPI class 300
Flange size	8.....	1 1/2-inch (40mm)
Flange material	▶ A..... B..... C.....	JIS S25C 304 SST *8 316 SST *8
Gasket contact surface*1	1..... 2.....	Serration (for ANSI flange only) Flat (no serration)
Wetted parts material (high pressure side) *7	WW.....	[Diaphragm] Hastelloy C-276 *6# [Others] 316 SST#
Flushing connection ring*2	▶ C..... D.....	[Ring] Reducer type [Vent/Drain plugs] R 1/4 connections *5 [Material] 316 SST # Reducer type 1/4 NPT connections 316 SST #
Extension	0.....	None
Fill fluid	▶ -A... -B... -D... -P...	[Process temperature]*3 [Ambient temperature] For high temperature use (Silicone oil) -10 to 250°C*4 -10 to 85°C For general use (Silicone oil) -40 to 120°C -40 to 85°C For oil prohibited use (Fluorinated oil)*9 -20 to 120°C -20 to 80°C For sanitary use (Propylene glycol) -10 to 120°C -10 to 85°C
Option codes		/□ Optional specification

The “▶” marks indicate the most typical selection for each specification.

Example: EJA210E-DMS5G-912NN-WA18B1WWC0-B/□

*1: See Table 3 'Gasket contact surface' on Page 4.

*2: When specified flushing connection ring code C or D, exclusive gasket is provided for transmitter side.

*3: Indicates the process temperature limit of high pressure side.

The process temperature limit for low pressure side is -40 to 120°C except fill fluid code -D.

*4: The distance 'S' is extended in 30mm.

*5: Not applicable for gasket contact surface code 1.

*6: Hastelloy C-276 or ASTM N10276

*7: ⚠ Users must consider the characteristics of selected wetted parts material and the influence of process fluids. The use of inappropriate materials can result in the leakage of corrosive process fluids and cause injury to personnel and/or damage to plant facilities. It is also possible that the diaphragm itself can be damaged and that material from the broken diaphragm and the fill fluid can contaminate the user's process fluids.

Be very careful with highly corrosive process fluids such as hydrochloric acid, sulfuric acid, hydrogen sulfide, sodium hypochlorite, and high-temperature steam (150°C [302°F] or above). Contact Yokogawa for detailed information of the wetted parts material.

*8: Forged version of the material may be used.

*9: Specify always with option code /K2 or /K6.

The '# marks indicate the construction materials conform to NACE material recommendations per MR0175 (2003).

Please refer to latest standards for details.

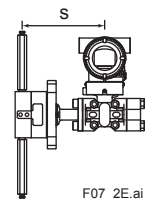

F07_2E.ai

II. Flange mounting section (Extended type)

● Process flange size: 4-inch (100mm)

EJA210E - [] [] [] [] - [] [] [] [] - E [] 4 [] [] [] [] [] [] []

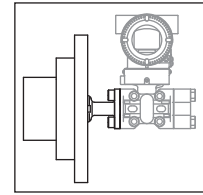

F08_1E.ai

Model	Suffix codes	Description
EJA210E	- [] [] [] [] - [] [] [] []	Transmitter body section (I)
Process connection style	-E	Extended type
Flange rating	J1 J2 A1 A2 P1 P2 D2 D4	JIS 10K JIS 20K ANSI class 150 ANSI class 300 JPI class 150 JPI class 300 DIN PN10/16 DIN PN25/40
Flange size	4	4-inch (100mm)
Flange material	A ▶ B C	JIS S25C 304 SST *5 316 SST *5
Gasket contact surface*1	1 2	Serration (for ANSI flange only) Flat (no serration)
Wetted parts material (high pressure side) *4	SE	[Diaphragm] 316L SST# [Others] 316 SST# [Pipe] 316 SST#
Flushing connection ring	0	None
Extension	1 3 5	Length (X2) = 50mm Length (X2) = 100mm Length (X2) = 150mm
Fill fluid	▶ -A ... -B ... -D ... -P ...	[Process temperature]*2 [Ambient temperature] For high temperature use (Silicone oil) -10 to 250°C*3 -10 to 85°C For general use (Silicone oil) -40 to 120°C -40 to 85°C For oil prohibited use (Fluorinated oil)*6 -20 to 120°C -20 to 80°C For sanitary use (Propylene glycol) -10 to 120°C -10 to 85°C
Option codes		/□ Optional specification

The “▶” marks indicate the most typical selection for each specification.

Example: EJA210E-DMS5G-912NN-EA14B1SE01-B/□

*1: See Table 3 'Gasket contact surface' on Page 4.

*2: Indicates the process temperature limit of high pressure side.
The process temperature limit for low pressure side is -40 to 120°C except fill fluid code -D.

*3: The distance 'S' is extended in 30mm.

*4: ⚠ Users must consider the characteristics of selected wetted parts material and the influence of process fluids. The use of inappropriate materials can result in the leakage of corrosive process fluids and cause injury to personnel and/or damage to plant facilities. It is also possible that the diaphragm itself can be damaged and that material from the broken diaphragm and the fill fluid can contaminate the user's process fluids.

Be very careful with highly corrosive process fluids such as hydrochloric acid, sulfuric acid, hydrogen sulfide, sodium hypochlorite, and high-temperature steam (150°C [302°F] or above). Contact Yokogawa for detailed information of the wetted parts material.

*5: Forged version of the material may be used.

*6: Specify always with option code /K2 or /K6.

The '# marks indicate the construction materials conform to NACE material recommendations per MR0175 (2003). Please refer to latest standards for details.

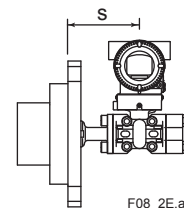

F08_2E.ai

II. Flange mounting section (Extended type)

- Process flange size: 3-inch (80mm)

EJA210E - [] [] [] [] - [] [] [] [] - E [] 3 [] [] [] [] [] [] [] []

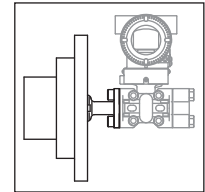

F09_1E.ai

Model	Suffix codes	Description
EJA210E	- [] [] [] [] - [] [] [] []	Transmitter body section (I)
Process connection style	-E	Extended type
Flange rating	J1 JIS 10K J2 JIS 20K A1 ANSI class 150 A2 ANSI class 300 P1 JPI class 150 P2 JPI class 300 D2 DIN PN10/16 D4 DIN PN25/40	
Flange size	3	3-inch (80mm)
Flange material	▶ A JIS S25C B 304 SST *6 C 316 SST *6	
Gasket contact surface*1	1 Serration (for ANSI flange only) 2 Flat (no serration)	
Wetted parts material (high pressure side) *5	WE	[Diaphragm] [Others] [Pipe] Hastelloy C-276 *4# 316 SST# 316 SST#
Flushing connection ring	0	None
Extension	1 Length (X2) = 50mm 3 Length (X2) = 100mm 5 Length (X2) = 150mm	
Fill fluid	▶ -A ... For high temperature use (Silicone oil) -B ... For general use (Silicone oil) -D ... For oil prohibited use (Fluorinated oil)*7 -P ... For sanitary use (Propylene glycol)	[Process temperature] ² [Ambient temperature] -10 to 250°C*3 -10 to 85°C -40 to 120°C -40 to 85°C -20 to 120°C -20 to 80°C -10 to 120°C -10 to 85°C
Option codes		/□ Optional specification

The “▶” marks indicate the most typical selection for each specification.

Example: EJA210E-DMS5G-912NN-EA13B1WE01-B/□

*1: See Table 3 ‘Gasket contact surface’ on Page 4.

*2: Indicates the process temperature limit of high pressure side.

The process temperature limit for low pressure side is -40 to 120°C except fill fluid code -D.

*3: The distance ‘S’ is extended in 30mm.

*4: Hastelloy C-276 or N10276

*5: ⚠ Users must consider the characteristics of selected wetted parts material and the influence of process fluids. The use of inappropriate materials can result in the leakage of corrosive process fluids and cause injury to personnel and/or damage to plant facilities. It is also possible that the diaphragm itself can be damaged and that material from the broken diaphragm and the fill fluid can contaminate the user’s process fluids.

Be very careful with highly corrosive process fluids such as hydrochloric acid, sulfuric acid, hydrogen sulfide, sodium hypochlorite, and high-temperature steam (150°C [302°F] or above). Contact Yokogawa for detailed information of the wetted parts material.

*6: Forged version of the material may be used.

*7: Specify always with option code /K2 or /K6.

The # marks indicate the construction materials conform to NACE material recommendations per MR0175 (2003).

Please refer to latest standards for details.

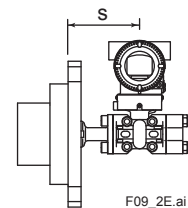

F09_2E.ai

■ OPTIONAL SPECIFICATIONS (For Explosion Protected type) “◇”

Item	Description	Code
Factory Mutual (FM)	FM Explosionproof Approval *1 Applicable Standard: FM3600, FM3615, FM3810, ANSI/NEMA 250 Explosionproof for Class I, Division 1, Groups B, C and D, Dust-ignitionproof for Class II/III, Division 1, Groups E, F and G, in Hazardous locations, indoors and outdoors (NEMA TYPE 4X) “FACTORY SEALED, CONDUIT SEAL NOT REQUIRED.” Temperature class: T6, Amb. Temp.: -40 to 60°C (-40 to 140°F)	FF1
	FM Intrinsically safe Approval *1 Applicable Standard: FM3600, FM3610, FM3611, FM3810 Intrinsically Safe for Class I, Division 1, Groups A, B, C & D, Class II, Division 1, Groups E, F & G and Class III, Division 1, Class I, Zone 0, in Hazardous Locations, AEx ia IIC Nonincendive for Class I, Division 2, Groups A, B, C & D, Class II, Division. 2, Groups F & G, Class I, Zone 2, Group IIC, in Hazardous Locations Enclosure: “NEMA TYPE 4X”, Temp. Class: T4, Amb. Temp.: -60 to 60°C (-75 to 140°F) Intrinsically Safe Apparatus Parameters [Groups A, B, C, D, E, F and G] Vmax=30 V, Imax=200 mA, Pmax=1 W, Ci=6 nF, Li=0 μH [Groups C, D, E, F and G] Vmax=30 V, Imax=225 mA, Pmax=1 W, Ci=6 nF, Li=0 μH	FS1
	Combined FF1 and FS1 *1	FU1
ATEX	ATEX Flameproof Approval *1 Applicable Standard: EN 60079-0:2009, EN 60079-1:2007, EN 60079-31:2009 Certificate: KEMA 07ATEX0109 X II 2G, 2D Ex d IIC T6...T4 Gb, Ex tb IIIC T85°C Db IP6X Degree of protection: IP66/IP67 Amb. Temp. (Tamb) for gas-proof: T4; -50 to 75°C (-58 to 167°F), T5; -50 to 80°C (-58 to 176°F), T6; -50 to 75°C (-58 to 167°F) Max. process Temp. for gas-proof (Tp): T4; 120°C (248°F), T5; 100°C (212°F), T6; 85°C (185°F) Max. surface Temp. for dust-proof: T85°C (Tamb: -30 to 75°C, Tp: 85°C) *2	KF22
	ATEX Intrinsically safe Approval *1 Applicable Standard: EN 60079-0:2009, EN 60079-11:2007, EN 60079:2012, EN 60079-26:2007, EN 61241-11:2006 Certificate: DEKRA 11ATEX0228 X II 1G, 2D Ex ia IIC T4 Ga, Ex ia IIIC T85°C T100°C T120°C Db Degree of protection: IP66/IP67 Amb. Temp. (Tamb) for EPL Ga: -50 to 60°C (-58 to 140°F) Maximum Process Temp. (Tp) for EPL Ga: 120°C Electrical data: Ui=30 V, Ii=200 mA, Pi=0.9 W, Ci=27.6 nF, Li=0 μH Amb. Temp. for EPL Db: -30 to 60°C *2 Max. surface Temp. for EPL Db: T85°C (Tp: 80°C), T100°C (Tp: 100°C), T120°C (Tp: 120°C)	KS21
	Combined KF22, KS21 and ATEX Intrinsically safe Ex ic *1 [ATEX Intrinsically safe Ex ic] Applicable Standard: EN 60079-0:2009, EN 60079-0:2012, EN 60079-11:2012 II 3G Ex ic IIC T4 Gc, Amb. Temp.: -30 to 60°C (-22 to 140°F) *2 Ui=30 V, Ci=27.6 nF, Li=0 μH	KU22

Item	Description	Code
Canadian Standards Association (CSA)	<p>CSA Explosionproof Approval *1 Certificate: 2014354 Applicable Standard: C22.2 No.0, C22.2 No.0.4, C22.2 No.0.5, C22.2 No.25, C22.2 No.30, C22.2 No.94, C22.2 No.60079-0, C22.2 No.60079-1, C22.2 No.61010-1 Explosion-proof for Class I, Groups B, C and D. Dustignition-proof for Class II/III, Groups E, F and G. When installed in Division 2, "SEAL NOT REQUIRED" Enclosure: NEMA TYPE 4X, Temp. Code: T6...T4 Ex d IIC T6...T4 Enclosure: IP66/IP67 Max.Process Temp.: T4;120°C(248°F), T5;100°C(212°F), T6; 85°C(185°F) Amb.Temp.: -50 to 75°C(-58 to 167°F) for T4, -50 to 80°C(-58 to 176°F) for T5, -50 to 75°C(-58 to 167°F) for T6 *2 Process Sealing Certification Dual Seal Certified by CSA to the requirement of ANSI/ISA 12.27.01 No additional sealing required Primary seal failure annunciation: at the zero adjustment screw</p> <p>CSA Intrinsically safe Approval *1 Certificate: 1606623 [For CSA C22.2] Applicable Standard: C22.2 No.0, C22.2 No.0.4, C22.2 No.25, C22.2 No.94, C22.2 No.157, C22.2 No.213, C22.2 No.61010-1, C22.2 No.60079-0 Intrinsically Safe for Class I, Division 1, Groups A, B, C & D, Class II, Division 1, Groups E, F & G, Class III, Division 1, Nonincendive for Class I, Division 2, Groups A, B, C & D, Class II, Division 2, Groups F & G, Class III, Division 1 Enclosure: NEMA TYPE 4X, Temp. Code: T4 Amb. Temp.: -50 to 60°C(-58 to 140°F) *2 Electrical Parameters: [Intrinsically Safe] Vmax=30V, Imax=200mA, Pmax=0.9W, Ci=10nF, Li=0 μH [Nonincendive] Vmax=30V, Ci=10nF, Li=0 μH [For CSA E60079] Applicable Standard: CAN/CSA E60079-11, CAN/CSA E60079-15, IEC 60529:2001 Ex ia IIC T4, Ex nL IIC T4 Enclosure: IP66/IP67 Amb. Temp.: -50 to 60°C(-58 to 140°F) *2, Max. Process Temp.: 120°C(248°F) Electrical Parameters: [Ex ia] Ui=30V, Ii=200mA, Pi=0.9W, Ci=10nF, Li=0 μH [Ex nL] Ui=30V, Ci=10nF, Li=0 μH Process Sealing Certification Dual Seal Certified by CSA to the requirement of ANSI/ISA 12.27.01 No additional sealing required Primary seal failure annunciation: at the zero adjustment screw</p> <p>Combined CF1 and CS1 *1</p>	<p>CF1</p> <p>CS1</p> <p>CU1</p>
IECEX	<p>IECEX Flameproof Approval *1 Applicable Standard: IEC 60079-0:2004, IEC60079-1:2003 Certificate: IECEX CSA 07.0008 Flameproof for Zone 1, Ex d IIC T6...T4 Enclosure: IP66/IP67 Max.Process Temp.: T4;120°C(248°F), T5;100°C(212°F), T6; 85°C(185°F) Amb.Temp.: -50 to 75°C(-58 to 167°F) for T4, -50 to 80°C(-58 to 176°F) for T5, -50 to 75°C(-58 to 167°F) for T6</p>	<p>SF2</p>

*1: Applicable for Electrical connection code 2, 4, 7, 9, C and D.
 *2: Lower limit of ambient temperature is -15°C (5°F) when /HE is specified.

OPTIONAL SPECIFICATIONS

Item		Description	Code	
Painting	Color change	Amplifier cover only *1	P□	
	Coating change	Amplifier cover and terminal cover, Munsell 7.5 R4/14 Anti-corrosion coating *1*2	PR X2	
316 SST exterior parts		316 SST zero-adjustment screw and setscrews *3	HC	
Fluoro-rubber O-ring		All O-rings of amplifier housing. Lower limit of ambient temperature: -15°C (5°F)	HE	
Lightning protector		Transmitter power supply voltage: 10.5 to 32 V DC (10.5 to 30 V DC for intrinsically safe type.) Allowable current: Max. 6000 A (1×40 μs), Repeating 1000 A (1×40 μs) 100 times Applicable Standards: IEC 61000-4-4, IEC 61000-4-5	A	
Oil-prohibited use		Degrease cleansing treatment	K1	
		Degrease cleansing with fluorinated oil filled capsule. *4 Operating temperature -20 to 80°C	K2	
Oil-prohibited use with dehydrating treatment		Degrease cleansing and dehydrating treatment	K5	
		Degrease cleansing and dehydrating treatment with fluorinated oil filled capsule. *4 Operating temperature -20 to 80°C	K6	
Calibration units *5		P calibration (psi unit)	D1	
		bar calibration (bar unit)	(See Table for Span and Range Limits.) D3	
		M calibration (kgf/cm ² unit)	D4	
Teflon film *6 *7		Diaphragm protection from sticky process fluid by FEP Teflon film attached with fluorinated oil. Operation range: 20 to 150°C, 0 to 2 MPa (Not applicable for vacuum service).	TF1	
Output limits and failure operation *8		Failure alarm down-scale: Output status at CPU failure and hardware error is -5%, 3.2mA DC or less.	C1	
		NAMUR NE43 Compliant Output signal limits: 3.8 mA to 20.5 mA	Failure alarm down-scale: Output status at CPU failure and hardware error is -5%, 3.2 mA DC or less. C2	
			Failure alarm up-scale: Output status at CPU failure and hardware error is 110%, 21.6 mA or more. C3	
Gold-plated diaphragm *9		Inside of isolating diaphragms (fill fluid side) are gold plated, effective for hydrogen permeation.	A1	
Wired tag plate		316 SST tag plate wired onto transmitter	N4	
Data configuration at factory*10		Data configuration for HART communication type	Software damping, Descriptor, Message CA	
		Data configuration for BRAIN communication type	Software damping CB	
Material certificate	For Flush type	High Pressure side: Process flange, Block *11 Low Pressure side: Cover flange	M0W	
		High Pressure side: Process flange, Block *12 Low Pressure side: Cover flange, Process connector	M1W	
		High Pressure side: Process flange, Block, Ring *11 *13 Low Pressure side: Cover flange	M3W	
		High Pressure side: Process flange, Block, Ring *12 *13 Low Pressure side: Cover flange, Process connector	M4W	
	For Extended type	High Pressure side: Process flange, Block, Pipe, Base *11 Low Pressure side: Cover flange	M0E	
		High Pressure side: Process flange, Block, Pipe, Base *12 Low Pressure side: Cover flange, Process connector	M1E	
Pressure test/ Leak test certificate *14*15		[Flange rating]	[Test pressure]	
		JIS 10K	2 MPa (290 psi)	Nitrogen (N ₂) Gas *17 Retention time: one minute
		JIS 20K	5 MPa (720 psi)	
		ANSI/JPI Class 150	3 MPa (430 psi)	
		ANSI/JPI Class 300	8 MPa (1160 psi) *6	
		ANSI/JPI Class 300	7 MPa (1000 psi) *16	
		T51		
		T54		
		T52		
		T56		
		T55		

-
- *1: Not applicable for amplifier housing code 2 and 3.
 - *2: Not applicable with color change option.
 - *3: 316 or 316L SST. The specification is included in amplifier code 2.
 - *4: Applicable only when fill fluid code -D is specified.
 - *5: The unit of MWP (Max. working pressure) on the name plate of a housing is the same unit as specified by option code D1, D3, and D4.
 - *6: Applicable for flush type (process connection style code W.)
 - *7: Applicable for flushing connection ring code 0.
 - *8: Applicable for output signal code D and J. The hardware error indicates faulty amplifier or capsule.
 - *9: Applicable for wetted parts material code SW, SE, WW, WE, and HW.
Consult Yokogawa in case gold-plated diaphragm is required for low pressure side.
 - *10: Also see 'Ordering Information.'
 - *11: Applicable for Low Pressure Side Process connection code 0 and 5.
 - *12: Applicable for Low Pressure Side Process connection code 1, 2, 3, and 4.
 - *13: Applicable for flushing connection ring code A, B, C, and D.
 - *14: The unit on the certificate is always MPa regardless of selection of option code D1, D3, or D4.
 - *15: A flushing connection ring will not be applied when conducting the pressure test or leak test.
 - *16: Applicable for extended type (process connection style code E.)
 - *17: Pure nitrogen gas is used for oil-prohibited use (option code K1, K2, K5, and K6.)

DIMENSIONS

• **Flush type**

Unit: mm (approx.inch)

- No ring (Flushing connection ring code 0)

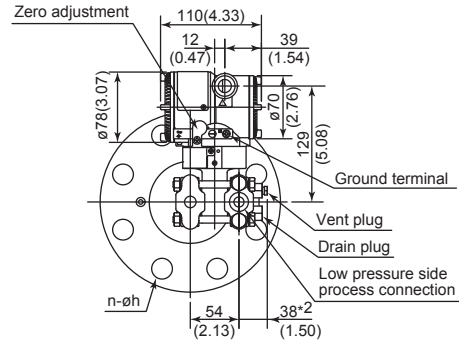
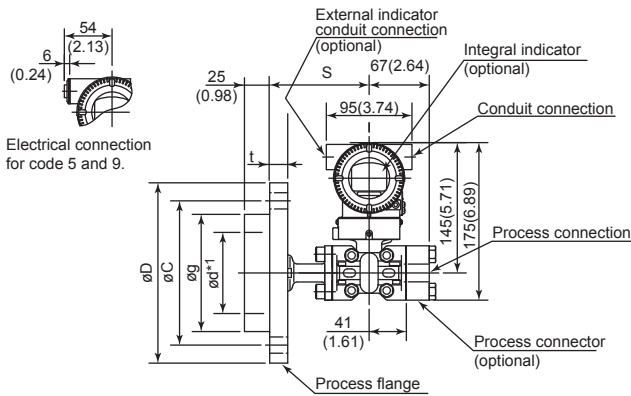

- With ring (Flushing connection ring code A, B, C, and D)

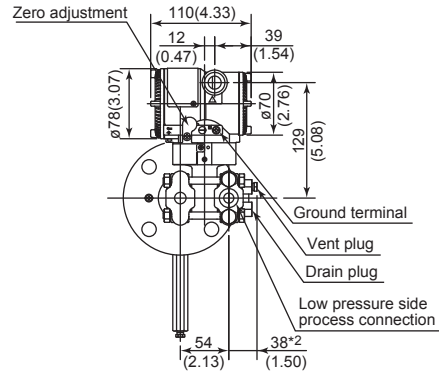
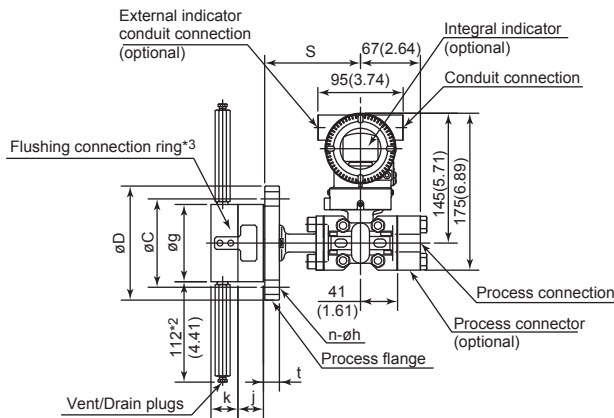

• **Extended type**

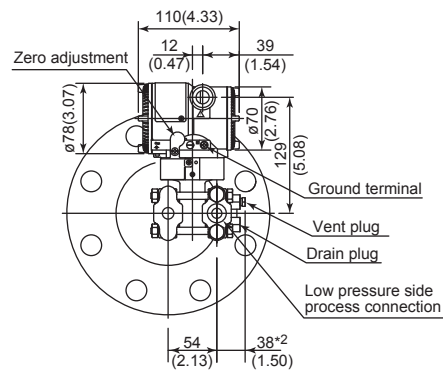
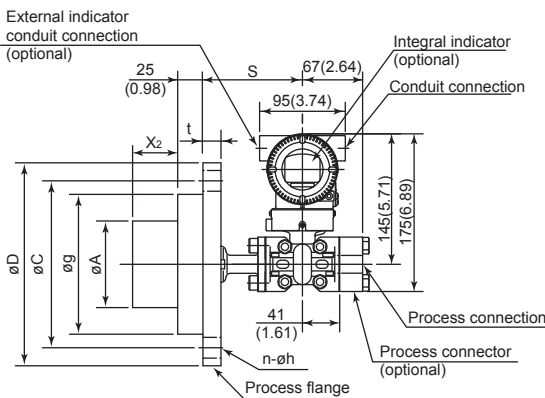

	Fill fluid code	S
General use	B and P	113(4.45)
High temperature use	A	143(5.63)

*1: Indicates inside diameter of gasket contact surface.
 *2: When option code K1, K2, K5, or K6 is selected, add 15 mm (0.59 inch) to the value in the flange.
 Add 11 mm (0.36 inch) for Vent/Drain plugs of flushing connection ring.

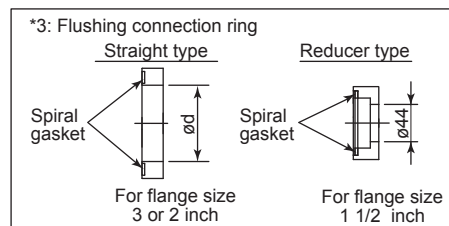

F10E.ai

Unit: mm (approx.inch)

Process flange size: 4 inch (100 mm)

Code	Flange rating	øD	øC	øg	ød	t	Bolt holes		j	k	øA
							No.(n)	Dia.(øh)			
J1	JIS 10K	210 (8.27)	175 (6.89)	155 (6.10)	—	18 (0.71)	8	19 (0.75)	—	—	96±0.5 (3.78±0.02)
J2	JIS 20K	225 (8.86)	185 (7.28)	155 (6.10)	—	24 (0.94)	8	23 (0.91)	—	—	96±0.5 (3.78±0.02)
A1	ANSI class 150	228.6 (9.00)	190.5 (7.50)	155 (6.10)	—	23.9 (0.94)	8	19.1 (0.75)	—	—	96±0.5 (3.78±0.02)
A2	ANSI class 300	254 (10.00)	200.2 (7.88)	155 (6.10)	—	31.8 (1.25)	8	22.4 (0.88)	—	—	96±0.5 (3.78±0.02)
P1	JPI class 150	229 (9.02)	190.5 (7.50)	155 (6.10)	—	24 (0.94)	8	19 (0.75)	—	—	96±0.5 (3.78±0.02)
P2	JPI class 300	254 (10.0)	200.2 (7.88)	155 (6.10)	—	32 (1.26)	8	22 (0.87)	—	—	96±0.5 (3.78±0.02)
D2	DIN PN10/16	220 (8.66)	180 (7.09)	155 (6.10)	—	20 (0.79)	8	18 (0.71)	—	—	96±0.5 (3.78±0.02)
D4	DIN PN25/40	235 (9.25)	190 (7.48)	155 (6.10)	—	24 (0.94)	8	22 (0.87)	—	—	96±0.5 (3.78±0.02)

Process flange size: 3 inch (80 mm)

Code	Flange rating	øD	øC	øg	ød*1	t	Bolt holes		j	k	øA
							No.(n)	Dia.(øh)			
J1	JIS 10K	185 (7.28)	150 (5.91)	130 (5.12)	90 (3.54)	18 (0.71)	8	19 (0.75)	25 (0.98)	27 (1.06)	71±0.5 (2.8±0.02)
J2	JIS 20K	200 (7.87)	160 (6.30)	130 (5.12)	90 (3.54)	22 (0.87)	8	23 (0.91)	25 (0.98)	27 (1.06)	71±0.5 (2.8±0.02)
A1	ANSI class 150	190.5 (7.50)	152.4 (6.00)	130 (5.12)	90 (3.54)	23.9 (0.94)	4	19.1 (0.75)	25 (0.98)	27 (1.06)	71±0.5 (2.8±0.02)
A2	ANSI class 300	209.6 (8.25)	168.1 (6.62)	130 (5.12)	90 (3.54)	28.5 (1.12)	8	22.4 (0.88)	25 (0.98)	27 (1.06)	71±0.5 (2.8±0.02)
P1	JPI class 150	190 (7.48)	152.4 (6.00)	130 (5.12)	90 (3.54)	24 (0.94)	4	19 (0.75)	25 (0.98)	27 (1.06)	71±0.5 (2.8±0.02)
P2	JPI class 300	210 (8.27)	168.1 (6.62)	130 (5.12)	90 (3.54)	28.5 (1.12)	8	22 (0.87)	25 (0.98)	27 (1.06)	71±0.5 (2.8±0.02)
D2	DIN PN10/16	200 (7.87)	160 (6.30)	130 (5.12)	90 (3.54)	20 (0.79)	8	18 (0.71)	25 (0.98)	27 (1.06)	71±0.5 (2.8±0.02)
D4	DIN PN25/40	200 (7.87)	160 (6.30)	130 (5.12)	90 (3.54)	24 (0.94)	8	18 (0.71)	25 (0.98)	27 (1.06)	71±0.5 (2.8±0.02)

Process flange size: 2 inch (50 mm)

Code	Flange rating	øD	øC	øg	ød*1	t	Bolt holes		j	k
							No.(n)	Dia.(øh)		
J1	JIS 10K	155 (6.10)	120 (4.72)	100 (3.94)	61 (2.40)	16 (0.63)	4	19 (0.75)	25 (0.98)	27 (1.06)
J2	JIS 20K	155 (6.10)	120 (4.72)	100 (3.94)	61 (2.40)	18 (0.71)	8	19 (0.75)	25 (0.98)	27 (1.06)
A1	ANSI class 150	152.4 (6.00)	120.7 (4.75)	100 (3.94)	61 (2.40)	19.1 (0.75)	4	19.1 (0.75)	25 (0.98)	27 (1.06)
A2	ANSI class 300	165.1 (6.50)	127.0 (5.00)	100 (3.94)	61 (2.40)	22.4 (0.88)	8	19.1 (0.75)	25 (0.98)	27 (1.06)
P1	JPI class 150	152 (5.98)	120.6 (4.75)	100 (3.94)	61 (2.40)	19.5 (0.77)	4	19 (0.75)	25 (0.98)	27 (1.06)
P2	JPI class 300	165 (6.50)	127.0 (5.00)	100 (3.94)	61 (2.40)	22.5 (0.89)	8	19 (0.75)	25 (0.98)	27 (1.06)
D2	DIN PN10/16	165 (6.50)	125 (4.92)	100 (3.94)	61 (2.40)	18 (0.71)	4	18 (0.71)	25 (0.98)	27 (1.06)
D4	DIN PN25/40	165 (6.50)	125 (4.92)	100 (3.94)	61 (2.40)	20 (0.79)	4	18 (0.71)	25 (0.98)	27 (1.06)

Process flange size: 1 1/2 inch (40 mm)

Code	Flange rating	øD	øC	øg	ød*1	t	Bolt holes		j	k
							No.(n)	Dia.(øh)		
J1	JIS 10K	140 (5.51)	105 (4.13)	86 (3.39)	44 (1.73)	16 (0.63)	4	19 (0.75)	27 (1.06)	30 (1.18)
J2	JIS 20K	140 (5.51)	105 (4.13)	86 (3.39)	44 (1.73)	18 (0.71)	4	19 (0.75)	27 (1.06)	30 (1.18)
A1	ANSI class 150	127 (5.00)	98.4 (3.87)	86 (3.39)	44 (1.73)	17.5 (0.69)	4	15.9 (0.63)	27 (1.06)	30 (1.18)
A2	ANSI class 300	155.4 (6.12)	114.3 (4.50)	86 (3.39)	44 (1.73)	20.6 (0.81)	4	22.4 (0.88)	27 (1.06)	30 (1.18)
P1	JPI class 150	127 (5.00)	98.6 (3.88)	86 (3.39)	44 (1.73)	17.6 (0.69)	4	16 (0.63)	27 (1.06)	30 (1.18)
P2	JPI class 300	155 (6.10)	114.3 (4.50)	86 (3.39)	44 (1.73)	20.6 (0.81)	4	22 (0.87)	27 (1.06)	30 (1.18)

*1: Indicates inside diameter of gasket contact surface.

Extension length (X2)

Extension code	X ₂
1	50 (1.97)
3	100 (3.94)
5	150 (5.91)

• **Terminal Configuration**

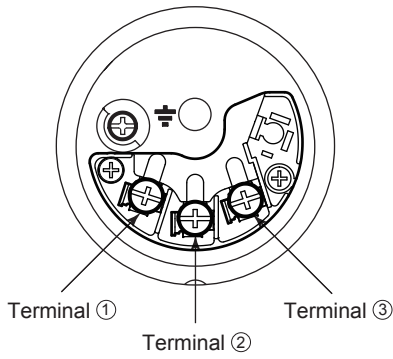

• **Terminal Wiring**

SUPPLY	+	①] Power supply and output terminals
	-	②	
CHECK	+	③] External indicator (ammeter) terminals*1*2
	-	②	
		⏏	Ground terminal

*1: When using an external indicator or check meter, the internal resistance must be 10 Ω or less.

*2: Not available for FOUNDATION Fieldbus and PROFIBUS PA communication types.

F11E.ai

< Ordering Information > “◇”

Specify the following when ordering

1. Model, suffix codes, and option codes
2. Calibration range and units:
 - 1) Calibration range can be specified with range value specifications up to 5 digits (excluding any decimal point) for low or high range limits within the range of -32000 to 32000. When reverse range is designated, specify LRV as greater than URV. When square root output mode is specified, LRV must be “0(zero)”.
 - 2) Specify only one unit from the table, ‘Factory setting.’
3. Display scale and units (for transmitters equipped with the integral indicator only)
Specify either 0 to 100 % or ‘Range and Unit’ for engineering units scale:
Scale range can be specified with range limit specifications up to 5 digits (excluding any decimal point) for low or high range limits within the range of -32000 to 32000. Unit display consists of 6-digit, therefore, if the specified scaling unit excluding ‘/’ is longer than 6-characters, the first 6 characters will be displayed on the unit display.
4. HART PROTOCOL
When output signal code is “J”, specify the HART protocol revision “5” or “7”.
5. TAG NO (if required)
Specified characters (up to 16 characters for BRAIN, 22 characters for HART) are engraved on the stainless steel tag plate fixed on the housing.
6. SOFTWARE TAG (for HART only, if required)
Specified characters (up to 32 characters) are set as “Tag” (the first 8 characters) and “Long tag”^{*1} (32 characters) in the amplifier memory. Use alphanumeric capital letters.
When the “SOFTWARE TAG” is not specified, specified “TAG NO” is set as “Tag” (the first 8 characters) and “Long tag”^{*1} (22 characters) in the amplifier memory.
^{*1}: applicable only when HART 7 is selected.
7. Other factory configurations (if required)
Specifying option code **CA** or **CB** will allow further configuration at factory. Following are configurable items and setting range.
[/CA : For HART communication type]
 - 1) Descriptor (up to 16 characters)
 - 2) Message (up to 30 characters)
 - 3) Software damping (0.00 to 100.00 s)
 [/CB : For BRAIN communication type]
 1) Software damping (0.00 to 100.00 s)

< Factory Setting >

Tag number	As specified in order
Software damping ^{*1}	‘2.00 s’ or as specified in order
Calibration range lower range value	As specified in order
Calibration range upper range value	As specified in order
Calibration range units	Selected from mmH ₂ O, mmH ₂ O(68°F), mmAq ^{*2} , mmWG ^{*2} , mmHg, Pa, hPa ^{*2} , kPa, MPa, mbar, bar, gf/cm ² , kgf/cm ² , inH ₂ O, inH ₂ O(68°F), inHg, ftH ₂ O, ftH ₂ O(68°F) or psi. (Only one unit can be specified.)
Display setting	Designated differential pressure value specified in order. (% or user scaled value.)
Static pressure display range	‘0 to 25 MPa’ for M and H capsule, absolute value. Measuring low pressure side.

^{*1}: To specify these items at factory, option code /**CA** or /**CB** is required.

^{*2}: Not available for HART protocol type.

< Material Cross Reference >

ASTM	JIS
316	SUS316
F316	SUSF316
316L	SUS316L
F316L	SUSF316L
304	SUS304
F304	SUSF304
660	SUH660
B7	SNB7
CF-8M	SCS14A